

Product Specifications

Motorola g20 Embedded GSM/GPRS Solution

VERSION 2.0

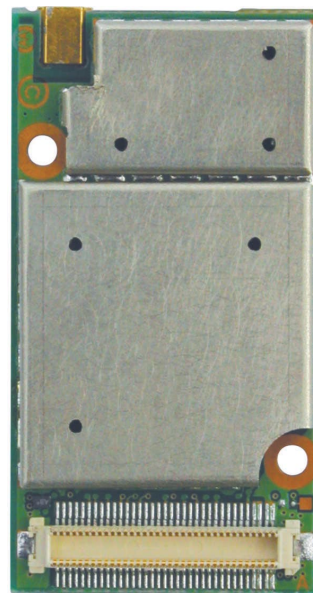

Motorola offers this information as a service to its customers, to support application and engineering efforts which use Motorola products. The information provided is based upon requirements specifically provided to Motorola by the customers. Motorola has not undertaken any independent search for additional relevant information, including any information that may be in the customer's possession. Furthermore, system validation of this Motorola product within a larger electronic system remains the responsibility of the customer or the customer's system integrator. All specifications supplied herein are subject to change without prior notice.

Motorola Confidential Proprietary

Revision History

Version	Date	Purpose
1.0	Feb 05, 2003	Creation
2.0	Sep 09, 2003	<ul style="list-style-type: none"> - Sales models and developer kit Part numbers updated – section 2 Page 4 - Product Features updated – section 3 Page 5 - 70 pin interface connector part number updated – section 4.1 page 6 - Specifications table updated with g20 size – section 5.5 page 17 - Specifications table updated with TX output power – section 5.5 page 17 - Mechanical drawings updated – section 5.6 page 18-19 - Safety/Governmental approvals section updated – section 7 page 20

Table of Contents

1. Introduction	4
2. Product Models and Developer’s Kit	4
3. Product Features	5
4. Application Interface	6
4.1 <i>Interface Connector.....</i>	<i>6</i>
4.2 <i>RF Connector</i>	<i>6</i>
4.3 <i>Interface Connector Pins Assignments</i>	<i>7</i>
4.4 <i>Interface Connector Pins Assignments by Functional Groups</i>	<i>9</i>
5. Functional Description.....	11
5.1 <i>Block Diagram</i>	<i>11</i>
5.2 <i>Power Management.....</i>	<i>11</i>
5.2.1 <i>Turning the g20 On/Off.....</i>	<i>12</i>
5.3 <i>Communication Interfaces</i>	<i>12</i>
5.3.1 <i>UART</i>	<i>12</i>
5.3.2 <i>USB</i>	<i>12</i>
5.3.3 <i>SIM Card</i>	<i>13</i>
5.4 <i>Audio Interfaces</i>	<i>14</i>
5.4.1 <i>Audio Path.....</i>	<i>14</i>
5.4.2 <i>Microphone Connectivity.....</i>	<i>15</i>
5.4.3 <i>Speaker Connectivity</i>	<i>15</i>
5.4.4 <i>Headset Connectivity</i>	<i>15</i>
5.4.5 <i>Alert Speaker Connectivity</i>	<i>16</i>
5.4.6 <i>PCM Audio (Digital Audio).....</i>	<i>16</i>
5.5 <i>Specifications</i>	<i>17</i>
5.6 <i>Mechanical Overview.....</i>	<i>18</i>
5.6.1 <i>Models F3001xx Through F3004xx.....</i>	<i>18</i>
5.6.2 <i>Models F3012xx and F3013xx.....</i>	<i>19</i>
6. SW Overview	20
7. Safety/Governmental approvals.....	20
8. Accessories	20

1. Introduction

The g20 is Motorola's newest family of embedded cellular products. Motorola continues its tradition of excellence by introducing this new cellular engine family for GSM communications.

The g20 is a dual-band GSM transceiver with exciting new features, advanced data services and high quality audio, all of which are delivered in a compact, easily embedded package. The g20 design incorporates all the necessary hardware and software interface features for integration in any application.

2. Product Models and Developer's Kit

The following table lists the available models of the g20 family.

g20 Model	Description
F3001xx	US Data Module 850/1900 W/3.0 mm stacking height Conn.
F3002xx	EURO Data Module 900/1800 W/3.0 mm stacking height Conn.
F3003xx	US Data Module 850/1900 W/USB W/ 3.0 mm stacking height Conn.
F3004xx	EURO Data Module 900/1800 W/USB W/ 3.0 mm stacking height Conn.
F3012xx	US Data Module 850/1900 W/2.5 mm stacking height Conn. W/USB driver
F3013xx	EURO Data Module 900/1800 W/2.5 mm stacking height Conn. W/USB driver

Note: The last 2 alpha characters of the sales models are for version control. For the latest model version, you may check it with your sales contact.

The following table gives the Developer's Kit part number.

Part Number	Description
F3030x	g20 Developer's Kit
FVN5245x	g20 Developer's Guide CD (CD is included in the Developer's Kit package – F3030A)

3. Product Features

All g20 family products support the following features:

- **Data**
 - **GPRS**
 - Multi slot class 8 (4 down; 1 up) Kbps
 - Coding Scheme CS1 – CS4
 - **Class B 07.10 multiplexing protocol (Dec 03)**
 - **CSD**
 - Max BR 14.4 Kbps
 - **SMS**
 - MO / MT Text mode
 - MO / MT PDU mode (Dec 03)
 - Cell broadcast
 - **FAX Class 1**
 - **Features over RS232**
 - Embedded TCP/IP stack
 - STK class II via serial port
 - DCE / DTE communication port
- **Voice**
 - **Digital PCM audio**
 - **Differential analog audio output signals**
 - **Two different Microphone inputs**
 - **Headset support**
 - **Vocoders** EFR/HR/FR/AMR
 - **Hands Free supported**
 - **Audio control**
 - Echo cancellation
 - Noise suppression
 - Side tone
 - Gain control
- **Supplementary Service**
 - **USSD**
 - **Call Forwarding**
 - **Call hold; waiting; multiparty**
 - **Call diverting**
 - **Missed call indicator**
 - **AOC**
 - **Call barring**
- **Control and Status Indicators**
 - **GPRS coverage**
 - **Wake up**
 - **Transmit slot indicator**
 - **Antenna Detect (Dec 03)**

4. Application Interface

The following section describes the connectivity and operation of the g20.

4.1 Interface Connector

The g20 uses a 70-pin 0.5mm pitch connector as a primary application interface. The connector hosts all the required power, data and GPIO functions to operate the g20 and to communicate with it.

g20 model Number	g20 70 Pin Connector	Mating Connector	Stacking Height
F3001xx – F3004xx	Molex 53748-0708	Molex 52991-0708	3.0mm
F3012xx – F3013xx	Molex 53885-0708	Molex 54102-0708	2.5mm

4.2 RF Connector

The g20 RF connector is a standard female MMCX interface connector used for an external antenna. An external antenna or antenna application must be connected to the g20 for adequate GSM reception. The antenna interface is matched at a 50 ohms impedance.

4.3 Interface Connector Pins Assignments

The following table lists the signals available at the interface connector.

Pin No.	Signal Name	Signal Function	I/O	Signal	Level		Internal PU/PD	Active H/L
					Typ.	Units		
1	GND	Ground		GND				
2	GND	Ground		GND				
3	GND	Ground		GND				
4	GND	Ground		GND				
5	VCC	Power supply	I	DC	3.6	V		
6	VCC	Power supply	I	DC	3.6	V		
7	VCC	Power supply	I	DC	3.6	V		
8	VCC	Power supply	I	DC	3.6	V		
9	RTS_N	RS232 RTS	I	Logic	2.775	V	69KΩ PU	L
10	USB_DET	USB connection detect	I	Logic	2.775	V	22KΩ PU	H
11	RXD_N	RS232 RXD	O	Logic	2.775	V	69KΩ PU	L
12	N.C.	Unused						
13	DSR_N	RS232 DSR	O	Logic	2.775	V	69KΩ PU	L
14	N.C.	Unused						
15	CTS_N	RS232 CTS	O	Logic	2.775	V	69KΩ PU	L
16	WAKEUP_IN_N	Wakeup input	I	Logic	2.775	V	22KΩ PU	L
17	DCD_N	RS232 DCD	O	Logic	2.775	V	69KΩ PU	L
18	PCM_DIN	Digital audio receive	I	Logic	2.775	V	69KΩ PD	H
19	DTR_N	RS232 DTR	I	Logic	2.775	V	69KΩ PD	L
20	PCM_DOUT	Digital audio transmit	O	Logic	2.775	V	69KΩ PU	H
21	TXD_N	RS232 TXD	I	Logic	2.775	V	69KΩ PU	L
22	PCM_CLK	Digital audio clock	O	Logic	2.775	V	69KΩ PD	H
23	RI_N	RS232 RI	O	Logic	2.775	V	69KΩ PU	L
24	PCM_FS	Digital audio frame sync.	O	Logic	2.775	V	69KΩ PD	H
25	RESET_N	Reset signal output	O	Logic	2.775	V		L
26	WAKEUP_OUT_N	Wakeup output	O	Logic	2.775	V	69KΩ PD	L
27	BL_SINK	Back light current sink		DC	100	mA		
28	KBC1_N	Keypad column 1	I	Logic	2.775	V	22KΩ PU	L
29	CHRG_DIS	Charger disable	O	Logic	2.775	V		H
30	KBC0_N	Keypad column 0	I	Logic	2.775	V	22KΩ PU	L
31	CHRG_SW	Accessory current control	O	Logic	2.775	V		
32	KBR0_N	Keypad row 0	I	Logic	2.775	V	22KΩ PU	L
33	CHRG_STATE	Charger rate indicator	I	Logic	2.775	V		
34	KBR1_N	Keypad row 1	I	Logic	2.775	V	22KΩ PU	L
35	CHRG_DET_N	Charger presence detect	I	Logic	2.775	V		L
36	KBR2_N	Keypad row 2	I	Logic	2.775	V	22KΩ PU	L
37	ENT_MUTE	Entertainment Mute	O	Logic	2.775	V	69KΩ PD	H
38	KBR3_N	Keypad row 3	I	Logic	2.775	V	22KΩ PU	L
39	TX_EN_N	GSM Transmit indicator	O	Logic	2.775	V	22KΩ PU	L
40	KBR4_N	Keypad row 4	I	Logic	2.775	V	22KΩ PU	L
41	ANT_DET	Antenna connection detect	O	Logic	2.775	V	47KΩ PU	H
42	KBR5_N	Keypad row 5	I	Logic	2.775	V	22KΩ PU	L
43	VIB_OUT	Vibrator regulator	O	DC	1.3	V		
44	SIM_RST_N	SIM reset	O	Logic	1.8/3	V	69KΩ PD	L
45	CHRG_TYP	Accessory type detect	I	Logic		V	47KΩ PU	
46	SIM_CLK	SIM clock	O	Logic	1.8/3	V	69KΩ PD	H
47	THERM	Temperature measurement	I	Logic		V	47KΩ PU	
48	SIM_VCC	SIM Vcc	O	DC	1.8/3	V		
49	GPRS_DET_N	GPRS coverage indicator	O	Logic	2.775	V	69KΩ PU	L
50	SIM_PD	SIM presence detect	I	Logic	2.775	V	69KΩ PU	L
51	IGN	Ignition input	I	Logic	3.6	V	47KΩ PD	H
52	SIM_DIO	SIM serial data	I/O	Logic	1.8/3	V	22KΩ PU	H
53	ON_OFF_N	On/Off switch	I	DC	3.6	V	22KΩ PU	L
54	LCD_CS	Display chip select	O	Logic	2.775	V		H

Pin No.	Signal Name	Signal Function	I/O	Signal	Level		Internal PU/PD	Active H/L
					Typ.	Units		
55	HDST_INT_N	Headset detect interrupt	I	Logic	2.775	V	270K PU	L
56	LCD_DATA	Display serial data	O	Logic	2.775	V		H
57	HDST_MIC	Headset microphone	I	Audio		V		
58	LCD_CLK	Display serial clock	O	Logic	2.775	V		H
59	MIC_GND	Microphone ground		GND		V		
60	LCD_RS	Display register select	O	Logic	2.775	V		H
61	MIC	Microphone input	I	Audio		V		
62	SPI_IRQ_N	SPI Interrupt	I	Logic	2.775	V	69KΩ PD	L
63	ALRT_N	Alert speaker inverted	O	Logic		V		
64	SPI_DIN	SPI MISO input	I	Logic	2.775	V	69KΩ PU	H
65	ALRT_P	Alert speaker	O	Audio		V		
66	SPI_CLK	SPI clock	O	Logic	2.775	V		H
67	SPKR_N	Speaker inverted	O	Audio		V		
68	SPI_DOUT	SPI MOSI output	O	Logic	2.775	V		H
69	SPKR_P	Speaker	O	Audio		V		
70	SPI_CS	SPI chip select	O	Logic	2.775	V	69KΩ PU	H

Note:

PU – Contains internal Pull-up resistor

PD - Contains internal Pull-down resistor

4.4 Interface Connector Pins Assignments by Functional Groups

Pin No.	Signal Name	Description	I/O	Signal	Level				Alternate Function	API Function
					Min	Typ	Max	Units		

Power

1	GND	Ground		GND						
2	GND	Ground		GND						
3	GND	Ground		GND						
4	GND	Ground		GND						
5	VCC	Power supply	I	DC	3.0	3.6	4.2	V		
6	VCC	Power supply	I	DC	3.0	3.6	4.2	V		
7	VCC	Power supply	I	DC	3.0	3.6	4.2	V		
8	VCC	Power supply	I	DC	3.0	3.6	4.2	V		

GPIO

16	WAKEUP_IN_N	g20 wakeup input	I	Logic		2.775		V		
26	WAKEUP_OUT_N	Wakeup output	O	Logic		2.775		V		
25	RESET_N	Reset signal output	O	Logic		2.775		V		
53	ON_OFF_N	On/Off switch	I	DC	3.0	3.6	4.2	V		
51	IGN	Ignition input	I	Logic	2.775	3.6	4.2	V		
39	TX_EN_N	GSM Transmit indicator	O	Logic		2.775		V		
41	ANT_DET	Antenna presence detect	O	Logic		2.775		V		
49	GPRS_DET_N	GPRS coverage indicator	O	Logic		2.775		V		
37	ENT_MUTE	Entertainment Mute	O	Logic		2.775		V		

UART

21	TXD_N	RS232 TXD	I	Logic		2.775		V	USB VMIN	
11	RXD_N	RS232 RXD	O	Logic		2.775		V	USB VPOUT	
9	RTS_N	RS232 RTS	I	Logic		2.775		V	USB XRXD	
15	CTS_N	RS232 CTS	O	Logic		2.775		V	USB VMOUT	
19	DTR_N	RS232 DTR	I	Logic		2.775		V	USB VPIN	
13	DSR_N	RS232 DSR	O	Logic		2.775		V	USB TXENB	
17	DCD_N	RS232 DCD	O	Logic		2.775		V	USB SUSPEND	
23	RI_N	RS232 RI	O	Logic		2.775		V	USB SOFTCON	

USB

10	USB_DET	USB connection detect	I	DC	4.4	5	5.25	V	USB_VBUS	
12	N.C.								USB_D+	
14	N.C.								USB_D-	

SPI

70	SPI_CS	SPI chip select	O	Logic		2.775		V		
62	SPI_IRQ_N	SPI Interrupt	I	Logic		2.775		V		
64	SPI_DIN	SPI MISO input	I	Logic		2.775		V		
68	SPI_DOUT	SPI MOSI output	O	Logic		2.775		V		
66	SPI_CLK	SPI clock	O	Logic		2.775		V		

SIM CARD

50	SIM_PD	SIM presence detect	I	Logic		2.775		V		
48	SIM_VCC	SIM Vcc	O	DC	1.8		3	V		
44	SIM_RST_N	SIM reset	O	Logic	1.8		3	V		
52	SIM_DIO	SIM serial data	I/O	Logic	1.8		3	V		
46	SIM_CLK	SIM clock	O	Logic	1.8		3	V		

Pin No.	Signal Name	Description	I/O	Signal	Level				Alternate Function	API Function
					Min	Typ	Max	Units		

PCM AUDIO

18	PCM_DIN	Digital audio receive	I	Logic		2.775		V		
20	PCM_DOUT	Digital audio transmit	O	Logic		2.775		V		
22	PCM_CLK	Digital audio clock	O	Logic		2.775		V		
24	PCM_FS	Digital audio frame sync.	O	Logic		2.775		V		

DISPLAY

54	LCD_CS	Display chip select	O	Logic		2.775		V		API GPIO9
60	LCD_RS	Display register select	O	Logic		2.775		V		API GPIO12
56	LCD_DATA	Display serial data	O	Logic		2.775		V		API GPIO10
58	LCD_CLK	Display serial clock	O	Logic		2.775		V		API GPIO11

KEYPAD

30	KBC0_N	Keypad column 0	I	Logic		2.775		V		API GPIO2
28	KBC1_N	Keypad column 1	I	Logic		2.775		V		API GPIO1
32	KBR0_N	Keypad row 0	I	Logic		2.775		V		API GPIO3
34	KBR1_N	Keypad row 1	I	Logic		2.775		V		API GPIO4
36	KBR2_N	Keypad row 2	I	Logic		2.775		V		API GPIO5
38	KBR3_N	Keypad row 3	I	Logic		2.775		V		API GPIO6
40	KBR4_N	Keypad row 4	I	Logic		2.775		V		API GPIO7
42	KBR5_N	Keypad row 5	I	Logic		2.775		V		API GPIO8

AUDIO

67	SPKR_N	Speaker inverted	O	Audio				V		
69	SPKR_P	Speaker	O	Audio				V		
63	ALRT_N	Alert speaker inverted	O	Logic				V		
65	ALRT_P	Alert speaker	O	Audio				V		
61	MIC	Microphone input	I	Audio				V		
59	MIC_GND	Microphone ground		GND				V		
57	HDST_MIC	Headset microphone	I	Audio				V		
55	HDST_INT_N	Headset detect interrupt	I	Logic		2.775		V		

CHARGER

35	CHRG_DET_N	Charger presence detect	I	Logic		2.775		V		
33	CHRG_STATE	Charger rate indicator	I	Logic		2.775		V		
31	CHRG_SW	Accessory current control	O	Logic		2.775		V		
29	CHRG_DIS	Charger disable	O	Logic		2.775		V		

ADC

45	CHRG_TYP	Accessory type detect	I	Logic	0		2.775	V		AD1
47	THERM	Temperature measurement	I	Logic	0		2.775	V		AD2

MISC

27	BL_SINK	Back light current sink	I	DC		80	100	mA		
43	VIB_OUT	Vibrator regulator	O	DC		1.3		V		

5. Functional Description

5.1 Block Diagram

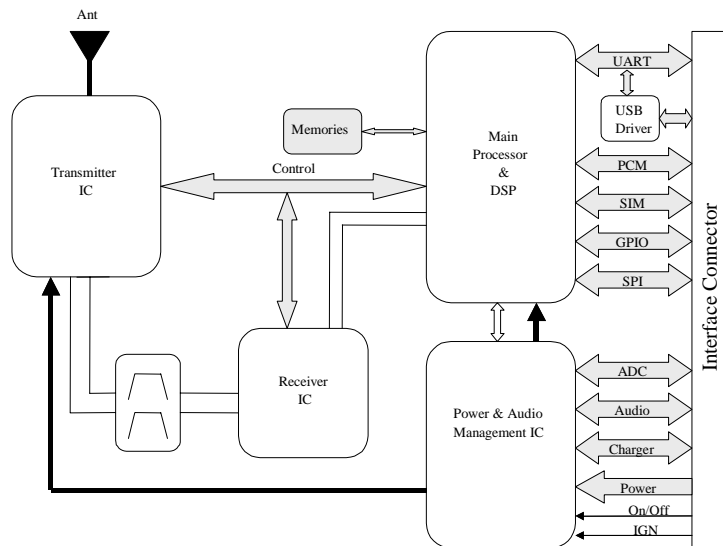

5.2 Power Management

The g20 is powered by an external DC power supply. The internal power management integrated chip (IC) is responsible for distributing the power within the g20. Using the external DC supply, the IC provides all the necessary internal regulation to power the g20 logic and analog circuits. The controller also hosts all the necessary circuitry to manage the analog audio interface of the g20. The range of operation of the g20 is 3.0V to 4.2V. The power supply should be able to drive 2.5A minimum.

The g20 current consumption parameters are as follows:

- Camped to the network and in Sleep mode: Less than 2.5mA (Typical 2.2mA)
- Searching for a network: Typical 20mA
- During a call at maximum power: Less than 350mA RMS (Typical 250mA RMS)

5.2.1 Turning the g20 On/Off

The g20 may be turned on or off using either of the following pins:

1. On/Off Pin (Pin #53).
This is a toggle input; any drop from high to low, for at least 600ms, will change the on/off status.
2. Ignition Pin (Pin #51).
This pin will turn on the unit when transitioning from low to high and will turn off the unit when transitioning from high to low. The signal state must remain constant for at least 600ms for power on detection, and for at least 300ms for power off detection.

5.3 Communication Interfaces

5.3.1 UART

The g20 UART is connected directly to the interface connector. The UART supports data rates of up to 115Kbps and both hardware and software flow control. The g20 supports Auto baud rate detect. The g20 incorporates a 9-pin RS232 connectivity to support all flow control modes: HW flow Control, SW flow Control or No flow Control. The UART signal names are DTE oriented.

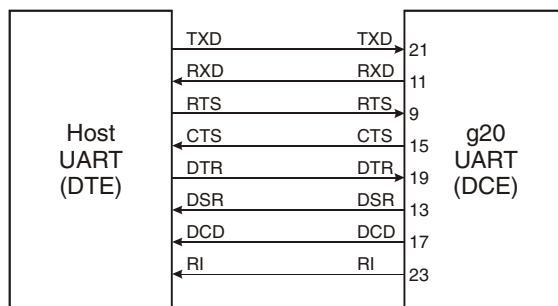

The UART signals are active low CMOS level signals, which can be connected directly to the application UART.

The RS232 levels are as follows:

Vih = 1.95 V min, 3.0 V max

Vil = 0.8 V max

Voh = 2.56 V min @100 uA

Vol = 0.2 V max @ 100 uA

5.3.2 USB

The g20 USB interface provides the required protocol to communicate on the Universal Serial Bus.

The USB interface supports the full speed data mode (12Mbps) and up to 12 endpoints. The g20 may be connected only as a device and not as a host or hub.

The Basic g20 models are supplied without the USB driver on board. The Driver is optional in the g20 board and can be also added externally.

Note: When the USB is used the RS232 driver in the DTE board should be in Tri-State mode for proper USB operation.

5.3.3 SIM Card

The g20 does not include an on-board SIM card connector, but supports an external SIM card application. The g20 interface connector includes the necessary signals for direct connection to an external SIM card. The SIM interface supports 1.8V and 3V SIM cards.

An example of SIM card connection is shown in the following figure:

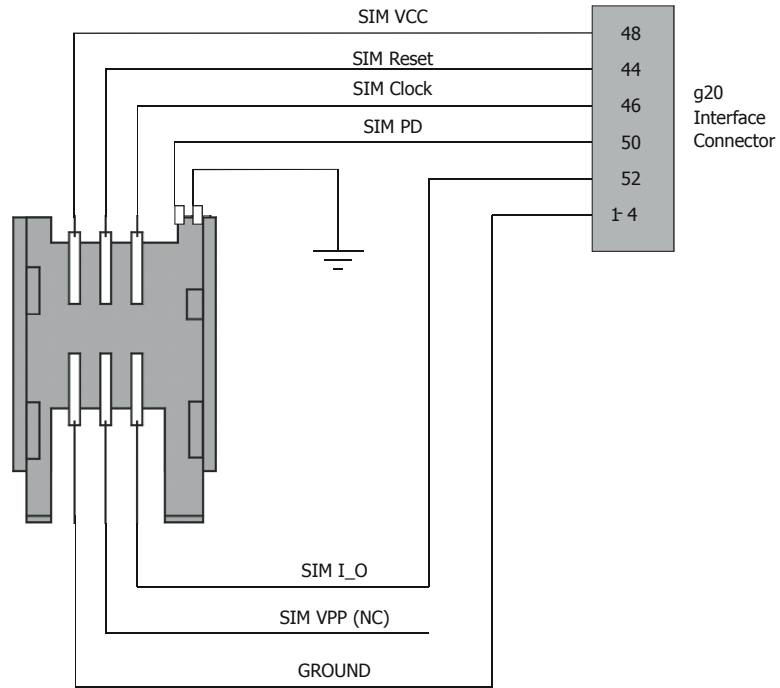

5.4 Audio Interfaces

The g20 audio interface supports several audio configurations, including hands free audio, handset audio and digital audio. The hands free audio, which includes a microphone, speaker and alert speaker, is the default audio interface.

5.4.1 Audio Path

The Audio path is shown in the figures below:

Speaker Path

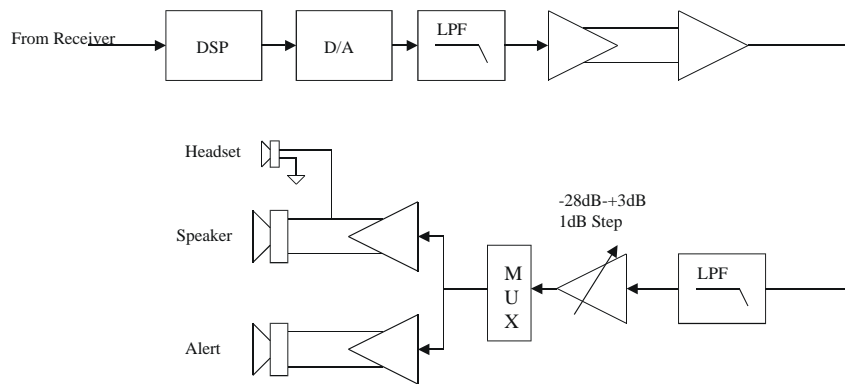

Microphone Path

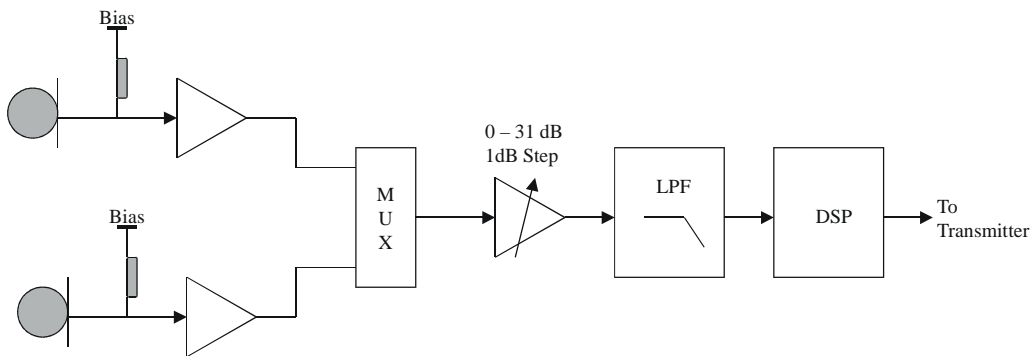

5.4.2 Microphone Connectivity

The microphone is the default analog audio input of the g20. The microphone input connects to the MIC input signal, and is a single-ended microphone that is referenced to the MIC_GND signal.

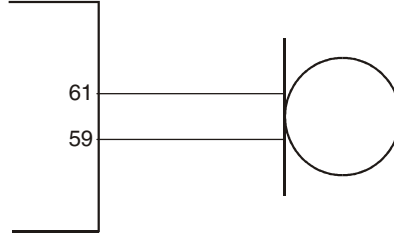

5.4.3 Speaker Connectivity

The g20 analog speaker output is differential, and includes the SPKR_N and SPKR_P signals. For single-ended speaker applications, it is recommended to use the SPKR_N signal referenced to MIC_GND.

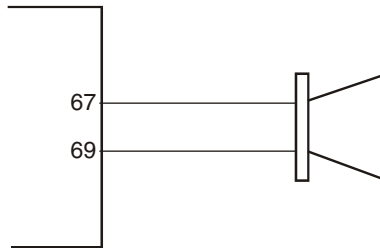

5.4.4 Headset Connectivity

The g20 headset configuration includes a microphone and a speaker, which are referenced to MIC_GND. The headset microphone input connects to the HDST_MIC signal and the headset speaker output connects to the SPKR_N pin. The headset cannot be used together with the hands free audio sources. The HDST_INT_N signal detects the insertion of a headset audio device and switches the g20 audio into headset mode.

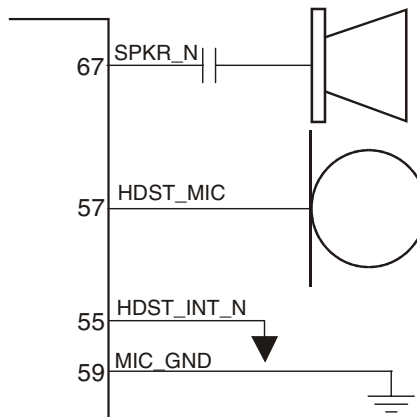

5.4.5 Alert Speaker Connectivity

The alert speaker is a differential output for a speaker or transducer, which is used to sound the phone ringer tones and other alert sounds. The output impedance is 8 ohms.

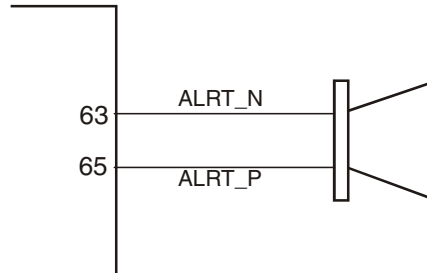

5.4.6 PCM Audio (Digital Audio)

The g20 PCM audio interface is a serial synchronous bus for digital audio applications. The serial audio bus includes data receive and transmit signals, a 512KHz clock signal and a 8KHz frame sync signal.

5.5 Specifications

Operating systems	
GSM Bands	900/1800 MHz 850/1900 MHz
Physical Specifications	
Size (F3001xx – F3004xx)	45.2 x 24.4 x 6.7 mm height refer to the distance between the customer's board and the g20 top level
Size (F3012xx – F3013xx)	45.2 x 24.4 x 6.2 mm height refer to the distance between the customer's board and the g20 top level
Mounting	Two 2.4mm Ø holes
Weight	11.9 gram
Volume	2.2 x 10 ³ mm ³
Electrical Specifications	
Operating Voltage	3.0 to 4.2V DC
Current consumption	In Call GSM 850 < 300mA; GSM 900 < 350mA; DCS 1800 / PCS 1900 < 350mA Standby < 2.5mA @DRX9 (Sleep mode) Off Current < 100uA
TX out power	GSM 850 29dBm ± 2dB GSM 900 33dBm ± 2dB DCS 1800 30dBm ± 2dB PCS 1900 30dBm ± 2dB
RX Sensitivity	< -102 dBm, Typical sensitivity will exceed -105 dBm
Environmental Specifications	
Operating temperature	-20°C +60°C
Functional temperature	-20°C +70°C
Storage temperature	-40°C +85°C
Thermal Shock	Six 4-hour cycles, from - 40°C to + 80°C, 24 hours total
Shock	20 g's with 11 millisecond duration, 20 impacts in three mutually perpendicular planes
Vibration	IS-19: 1.5g acceleration, 5 to 500 Hz @ 0.1 octave/minute in three mutually perpendicular planes
Interfaces	
SIM	Socket not included. Lines are driven to the interface connector. Supports SIM of 1.8V or 3V
RS232	9 lines RS232 Serial Asynchronous full flow control, 2.775V logic level (DCE flow direction) Vih 1.95 V min, 3.0 V max Vil 0.8 V max Voh 2.56 V min @100 uA Vol 0.2 V max @ 100 uA
USB	Two available options: 1. USB driver is included 2. USB driver is not included
SPI	Port used for diagnostics purposes

5.6 Mechanical Overview

5.6.1 Models F3001xx Through F3004xx

5.6.1.1 Top View

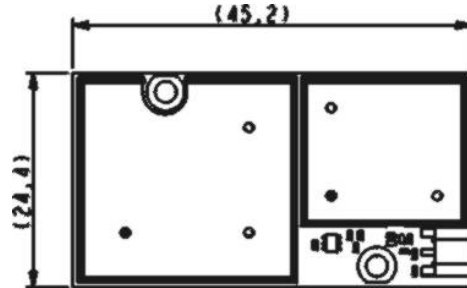

5.6.1.2 Bottom View

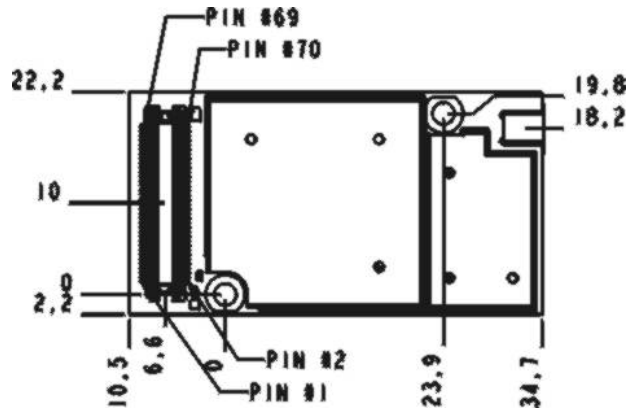

5.6.1.3 Side View

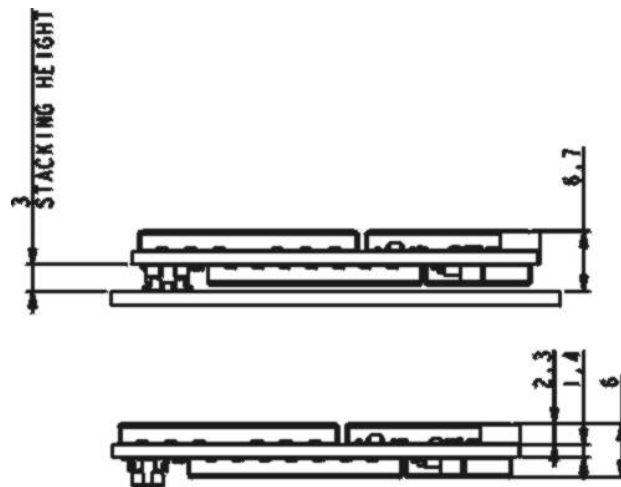

5.6.2 Models F3012xx and F3013xx

5.6.2.1 Top View

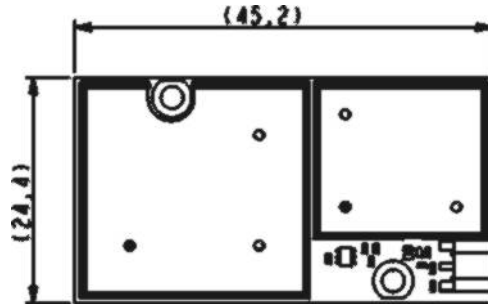

5.6.2.2 Bottom View

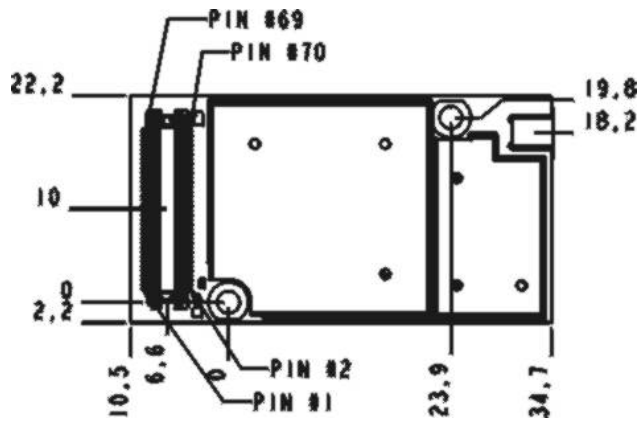

5.6.2.3 Side View

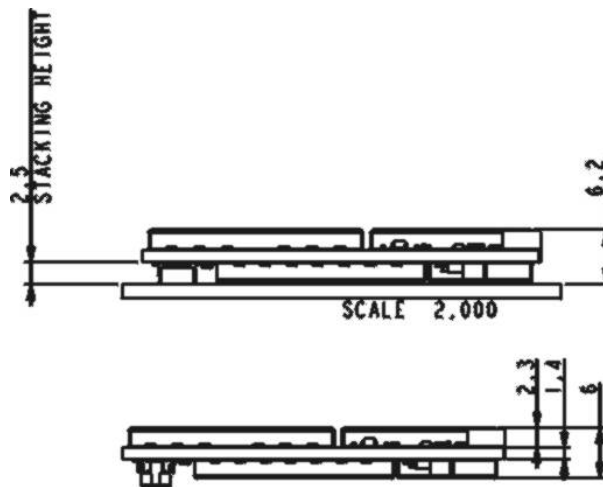

6. SW Overview

The g20 supports the following AT commands set:

- AT Commands according to GSM 07.05
- AT Commands according to GSM 07.07
- Motorola proprietary AT commands

7. Safety/Governmental approvals

The g20 module complies with the following standards:

- FCC
- PTCRB
- R&TTE
- GCF (Dec 03)
- EMC (CE)
- IC (Industry Canada)

8. Accessories

- Developer's Kit
- Developer's Guide
- Firmware data loader (Dec 03)
- Logger