



EVERLIGHT ELECTRONICS CO.,LTD.

Device Number : DLE-125-003 REV: 1.1

3mm Round Small Flange Without stand-off LEDs, T-1

MODEL NO : 1254ID ECN : _____ Page: 1/4

Features :

- High luminous power.
- Can be driven at low current.
- 2.54mm lead spacing.
- Available on tape and reel.

Description :

- The series is specially designed for applications require higher brightness than that achievable with standard lamp.
- The LED lamps are available with different colors,intensities, epoxy colors, etc.

Package Dimension:

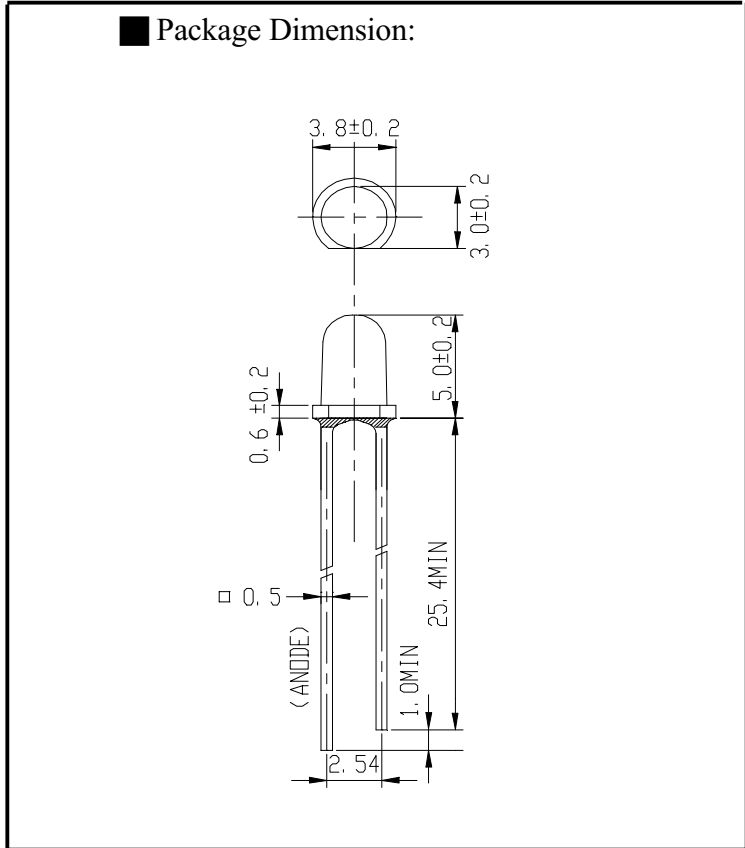

Applications :

- TV Set
- Monitor
- Telephone
- Computer

NOTES :

- 1.All dimensions are in millimeters.
- 2.An epoxy meniscus may extend about 1.5mm(0.059") down to the lead.

| PART NO | CHIP | | Lens Color |
|---------|-----------|---------------|--------------|
| | Material | Emitted Color | |
| 1254ID | GaAsP/GaP | Hi-Eff Red | Red Diffused |

| DESIGNER | CHECKER | APPROVER |
|----------|---------|----------|
| | | |

Office : NO 25,Lane 76,Chung Yang Rd,Sec.3
Tucheng,Taipei 236,Taiwan,R.O.C.

TEL : 886-2-2267-2000,2267-9936(22 Lines)
FAX : 886-2-2267-6189



Device Number : DLE-125-018 REV: 1.1

3mm Round Small Flange Without stand-off LEDs, T-1

MODEL NO 1254ID ECN : _____ Page: 3/4

■ Typical Electro-Optical Characteristic Curves

